



***Facility Study
For
Generation Interconnection
Request
GEN-2010-053***

***SPP Generation
Interconnection***

(#GEN-2010-053)

December 2011

Summary

ITC Great Plains (ITCGP) performed a detailed Facility Study at the request of Southwest Power Pool (SPP) for Generation Interconnection request GEN-2010-053. The request for interconnection was placed with SPP in accordance with SPP's Open Access Transmission Tariff, which covers new generation interconnections on SPP's transmission system.

Interconnection Customer Interconnection Facilities

The Interconnection Customer will be responsible for the 345 kV transmission line from its wind turbine Collector Substation to the Point of Interconnection (POI), the Clark County 345kV substation located in Clark County, Kansas. In addition, the customer will be responsible for reactive power compensation equipment to maintain 95% lagging (providing vars) and 95% leading (absorbing vars) power factor at the point of interconnection.

Transmission Owner Interconnection Facilities and Non-Shared Network Upgrades

Per the following Facility Study, the Interconnection Customer is responsible for **\$3,715,000** of Transmission Owner Interconnection Facilities and non-shared network upgrades.

Shared Network Upgrades

The interconnection customer was studied within the DISIS-2010-002 Impact Restudy. At this time, the Interconnection Customer is allocated the following cost for shared network upgrades:

Upgrade Description	Allocated Cost	Total Cost
Beaver County – Gray County 345kV. Build 345kV transmission line between Beaver County and Kansas State Line. Includes substation work at Beaver County. (Construction by OG&E)	\$14,952,314	\$105,609,050
Beaver County – Gray County 345kV. Build 48 miles of 345kV transmission line between Gray County and Oklahoma State Line. Includes construction of additional 345kV line terminal with reactor at Gray County. (Construction by Sunflower)	\$9,146,181	\$64,600,000
Total	\$24,098,496	

If higher queued interconnection customers withdraw from the queue, suspend or terminate their GIA, restudies will have to be conducted to determine the Interconnection Customers' allocation of shared network upgrades. All studies have been conducted on the basis of higher queued interconnection requests and the upgrades associated with those higher queued interconnection requests being placed in service.

Additional Required Network Upgrades

Certain Network Upgrades that are not the cost responsibility of the Customer are required for Interconnection. These Network Upgrades include:

1. Spearville – Clark – Medicine Lodge – Wichita double circuit 345kV transmission line
2. Medicine Lodge – Woodward double circuit 345kV transmission line

These network upgrades are not schedule to be in service until December 31, 2014. Depending upon the status of higher or equally queued customers, the Interconnection Customer's in service date may be delayed until the in service date of these Network Upgrades.



**FACILITY STUDY
for
Generation Interconnection Request 2010-053**

199.8 MW Wind Generating Facility
In Ford County, Kansas

October 5, 2011

Executive Summary

ITC Great Plains (“ITCGP”) has performed a facility study at the request of Southwest Power Pool (“SPP”) for Generation Interconnection request GEN-2010-053 under the SPP Open Access Transmission Tariff. The subject request entails interconnecting a 199.8 MW wind powered generation facility in southeastern Ford County, Kansas. The project will interconnect to the new Clark County Switching Station scheduled for completion no later than December 31, 2014.

ITCGP estimates the cost of the customer’s interconnection facilities will be \$3,715,000 including applicable company overheads and tax gross-ups, in 2014 dollars. It is further estimated that the required legal/real estate acquisition and construction activities will require 603 days, or approximately 20 months. However, in no case can the interconnection facilities be placed in service prior to completion of the Clark County Switching Station. The attached report contains additional details regarding the estimate as well results of short circuit studies, review of reactive compensation, and information on voltage guidelines.

1.0 Introduction

ITC Great Plains (“ITCGP”) performed the following study at the request of Southwest Power Pool (“SPP”) for Generation Interconnection request GEN-2010-053 under the SPP Open Access Transmission Tariff (“OATT”). Subject request entails interconnecting a 199.8 MW wind powered generation facility in southeastern Ford County, Kansas. The project will interconnect to the future Clark County Switching Station scheduled for completion no later than December 31, 2014. The ITCGP scope of this Facility Study was to provide a cost estimate for the Customer’s interconnection facilities.

2.0 Interconnection Facilities

The Customer’s interconnection request indicated that the new wind generation project’s substation facilities would be located such that the interconnection substation and the Customer’s substation would be interconnected via approximately 18 miles of single-circuit 345 kV transmission line.

Figure 1 – Clark County Switching Station with Gen-2010-053 Interconnection

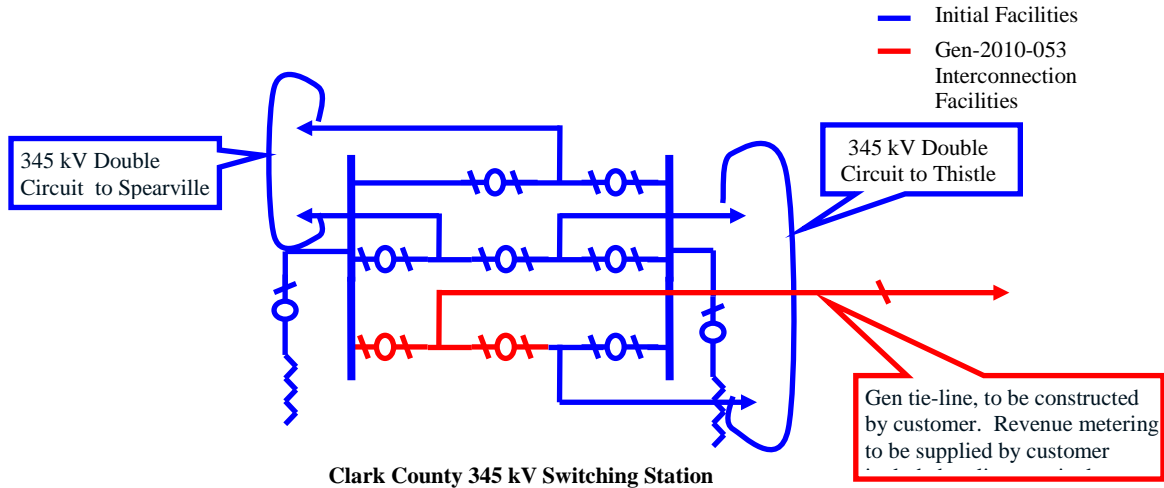
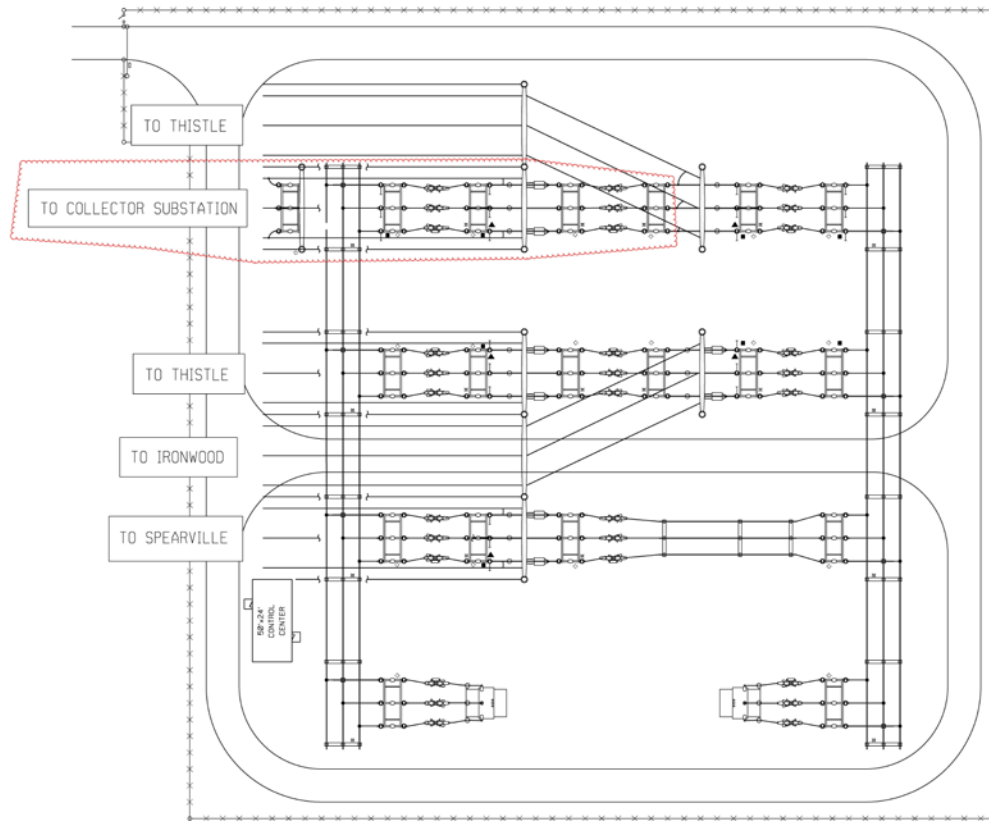

Figure 2 – Interconnection (clouded in red) at Clark County Switch Station



Design Criteria:

The Transmission Owner’s standards will be applicable. Where no applicable standards are available, the Transmission Owner will substitute industry standards and other good utility practices.

One-Line Diagrams:

See Figure 1 for Transmission Owner One-Line.

Site Plan:

See Figure 2 for site plan of Transmission Owner switching station at Clark County. The equipment that needs added to accommodate the customer’s interconnection request is clouded in red.

Route Information:

N/A

Right-of-Way Information:

It is assumed that the interconnection customer will be responsible for building the 345 kV line required to connect the Clark County Switching Station with the

customer's substation. As such, the interconnection costs contained herein do not include any costs for extending the ITCGP transmission line.

Permitting:

The Interconnection Customer will be responsible for satisfying all community or governmental site plan or zoning approval requirements which may include wetland or flood plain permits. The Transmission Owner will be responsible for the control center building permit and the KDHE storm water construction permits associated with the Transmission Owner portions of the construction.

Metering & Ownership Demarcation:

The Interconnection Customer or others will provide, own, operate and maintain revenue metering. The specifics of the revenue metering will be defined during the detailed engineering phase of the project. The customer must cooperate with the Transmission Provider and Local Transmission Owner requirements in the metering design. Revenue metering equipment will be required at the Point of Interchange in the Transmission Owner's substation.

The ownership demarcation will be at the transition across the security fence of the Transmission Owner substation.

Protection & Control Overview:

One set of three 345kV CCVTs will be installed for the Gen-2010-53 line terminal.

Two paths of fiber optic cable will be required for the line.

Two 345kV breaker control panels with microprocessor based relays will be installed. Breaker failure protection, automatic reclosing supervised by synchronism check will be provided.

One 345kV line relaying panel with microprocessor based relays will be installed.

Insulation Coordination:

345kV, 1050kV BIL

Short Circuit Study Results - Bus Fault Levels:

ITCGP calculated bus fault levels for the interconnection substation and adjacent substations to determine if the added generation will cause fault currents to exceed interrupting ratings for existing equipment and for use in sizing future equipment. Calculations are based on data for the interconnection transformer and installed wind turbines supplied by the Interconnection Customer. Variance from supplied data could materially change calculated short circuit values. Results are displayed in Table 1.

Table 1 – Short Circuit Results

Fault Location	Fault Current (Amps)*	
	Three-Phase	Line-Ground
Spearville Substation	10697	9462
Clark County 345 kV Bus	10078	8410
Thistle 345 kV Bus	12012	9753
* The fault currents are estimated for the following 345kV line contributions: Thistle-Wichita #1, Thistle-Wichita #2, Thistle-Woodward #1 and Thistle-Woodward #2		

Fault currents shown in Table 1 are within the circuit breaker interrupting capabilities with the addition of 199.8 MW contributed by Gen-2010-053.

Reactive Compensation:

ITCGP evaluated the impact of the proposed interconnection on the reactors presently planned for the Clark County Switching Station and Thistle Substation facilities. ITCGP studies determined that the planned reactors will not be materially affected by the planned interconnection.

Voltage Guidelines:

Reactive power, voltage regulation and operating requirements will be per Transmission Operator (TOP) and Transmission Provider directives. Interconnection Customer will operate the Generating Facility to a voltage schedule of 354 kV (1.026 pu) with a bandwidth of +/- 6 kV (0.017 pu) at the Point of Interconnection utilizing the Generating Facility’s required power factor design capability as indicated in SPP DISIS-2010-002 Relevant language from the SPP DISIS is included below for reference:

“Per FERC and SPP Tariff requirements, if the power factor needed to maintain scheduled voltage is less than 0.95 lagging, then the requirement is limited to 0.95 lagging. The lower limit for leading power factor requirement is also 0.95. If a project never operated leading under any contingency, then the leading requirement is set to 1.0. The same applies on the lagging side.

Power factor analysis using the original requester data showed a need for 81 Mvar of capacitors at GEN-2010-027 and 23 Mvar at GEN-2010-052. However, after the modifications discussed previously, GEN-2010-027 needs no capacitors and GEN-2010-052 needs only 7 Mvar. GEN-2010-053 requires at least 83 Mvar of capacitors to meet its power factor requirement due to the lack of any reactive power capability in the Vestas V90 wind turbines. GEN-2010-045 needs at least 9 Mvar and GEN-2010-049 needs at least 2 Mvar. The final power factor requirements are shown in Table 4-2 below. These are only the minimum power factor ranges

based on steady-state analysis. A project developer may install more capability than this if desired.”

For further clarification, the Customer may meet the +/-95% power factor requirement by means other than capacitor banks such as reactive capability from the wind generators. Also, any capacitor banks installed by the Customer shall not cause voltage distortion in accordance with Article 9.7.6 Power Quality of the Generation Interconnection Agreement

The Interconnection Customer will regulate the Generating Facility’s voltage to the specified set-point within the defined bandwidth stated above using an automatic voltage controller utilizing the inherent reactive power capability in the wind turbines and static capacitor banks. The Interconnection Customer is required to have a generator operator available for 24/7 communication with the TOP. The TOP may, at any time request a variance from the schedule in response to system operating/security requirements.

Other Equipments & Materials:

- Gas Circuit Breakers (GCB):
Two (2) 345 kV, 3000A rated, 1300 kV BIL, 50 kAIC GCBs.

- Disconnect Switch:
Five (5) 345 kV, 3000A rated, 63kA, 1050 kV BIL disconnect switches.

- CCVTs:
Three (3) 345 kV, 3-winding, 1300kV BIL CCVTs.

- Insulators:
Six (6) 345 kV, 1050 kV BIL station post, porcelain insulators.

- Surge Arresters:
Six (6) 345 kV, vertical mount, 209 kV MCOV, polymer surge arresters

- Control Cable:
Control cables per Transmission Owner standards will be installed in direct buried PVC conduits, above grade IMG conduits and in pre-cast cable trench. All control cables from the yard will be terminated at the relaying control panels. The control building will have overhead cable trays for necessary cable runs and inter-panel connections.

Relaying, Control, & SCADA:

- Relay Panels:
 - Two (2) 345kV Breaker Control & Breaker Failure panels
 - One (1) SEL 311L Line Relaying Panel

Grounding System:

The grounding system will be designed and installed per Transmission Owner’s standards. These standards follow the IEEE 80 standards.

Lightning Shielding Design:

Lightning shielding will be provided per Transmission Owner’s standards. Multiple H-frame structures along with shield wire, will be used for lightning protection.

Yard Lighting:

Yard lighting will be installed to be sufficient for visual indication of the disconnect switch positions or egress of personnel, and will not serve as task lighting.

Structures:

The required new outdoor steel structures listed below will be hot-dipped galvanized wide flange structures:

- Five (5) 345 kV intermediate height disconnect switch stands
- Two (2) H-frame line entrance structures
- Three (3) 345 kV CCVT stands
- Six (6) 345 kV surge arrester stands

Scheduling Requirements:

Legal/Real Estate Procurement	65 days
Material Procurement / Design	185 days
Substation Construction	252 days
Closeout Activities	30 days

Note – in no case can the requested interconnection be completed prior to in-service date of the Clark County Switching Station

Total Cost Estimate Accuracy: +/- 20%

Total Project Cost: \$3,715,000

Note that the cost estimate provided is in expressed in 2014 terms and includes applicable company overheads and potential tax gross-ups.